

# MVL-HF1624M-10MP

## 1/1.8"16mm 10MP FA LENS

HF-P series FA Lens are optimized for machine vision light sources and sensor, with high resolution, excellent image quality, high transmittance and good stability. Featured with fixed focal length, manual aperture and compact size, it is suitable for machine vision industry applications and ideal for industrial cameras.



### Key Features

- Ultra high resolution and consistency of image clarity
- Bigger aperture, lower distortion and higher relative illumination rate
- Achromatic optical system design, Better imaging performance with color camera
- Excellent vibration resistance performance, optical axis shifting within pixel level
- Good stability at high and low temperature
- Multilayer and broadband coating design, compatible with visible and near-infrared applications

### Distortion

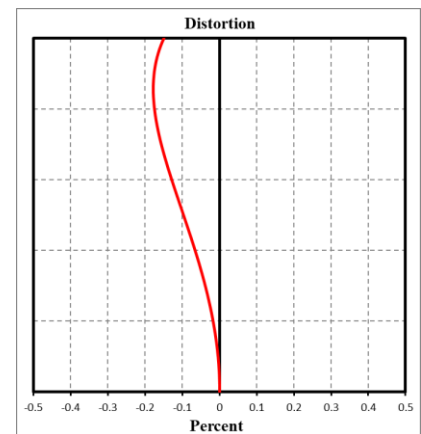

### MTF

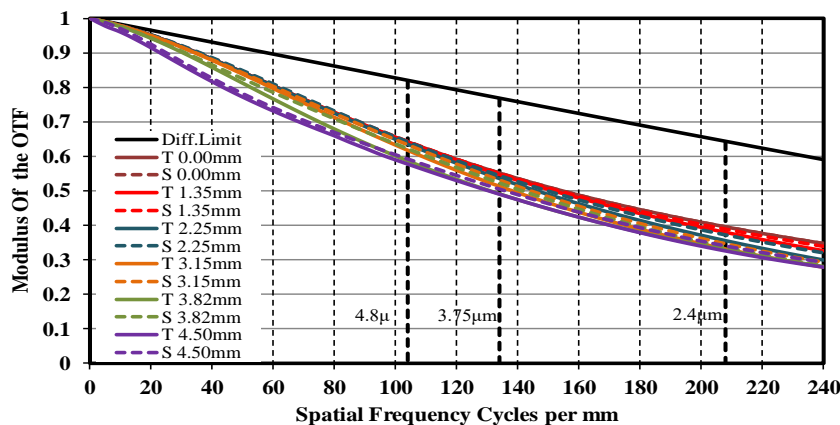

### Relative Illumination

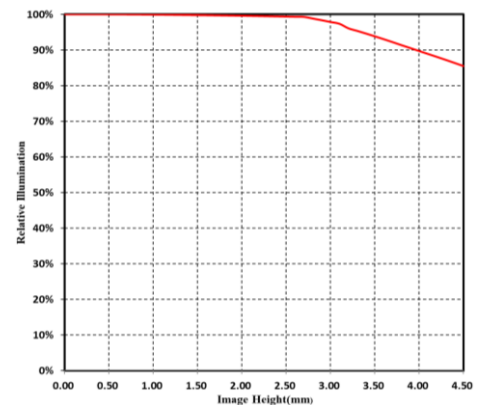

Note: The above curves are the simulate results based on F2.4,  $\beta=-0.039$ , WD=400 mm.

## Specification

Model	MVL-HF1624M-10MP
Parameter	Fixed focal length, Manual iris, 10MP, FA Lens
<b>Performance</b>	
Focal length	16 mm
F-number	F2.4 to F16
Image size	Ø9 mm (1/1.8")
Distortion	-0.02%
Minimum object distance	0.1 m
Field of view	D (8.96 mm): 30.17° H (7.38 mm): 25.07° V (4.92 mm): 16.92°
<b>Mechanical</b>	
Iris control	Manual
Focus control	Manual
Filter thread	M27 × 0.5
Mount	C-mount
Flange back length	17.526 mm
Dimension	Ø29 mm × 38.36 mm (Ø1.1" x 1.5")
Weight	70.2 g (0.2 lb.)
Temperature	-10°C to 50°C (14 °F to 122 °F)
<b>General</b>	
Certification	RoHS 2.0

## Dimension

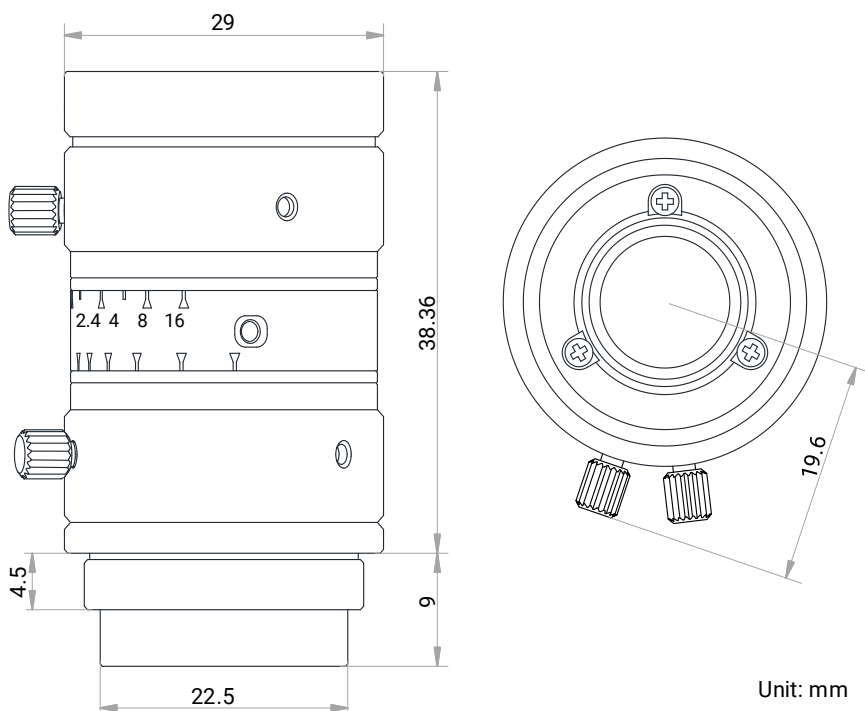

## Field of View

Extension (mm)	Working Distance (mm)		Magnification	Field of View (mm)			
				1/1.8"		1/2"	
				H(7.38mm)	V(4.92mm)	H(6.22mm)	V(4.67mm)
10	near	6.6	-0.778	9.61	6.36	8.07	6.04
	far	11.5	-0.607	12.37	8.17	10.37	7.75
5	near	20.6	-0.459	16.28	10.79	13.67	10.23
	far	38.3	-0.305	24.50	16.22	20.57	15.39
2	near	45.2	-0.267	27.91	18.53	23.47	17.58
	far	118	-0.123	60.36	40.09	50.77	38.04
1	near	64	-0.202	36.77	24.43	30.94	23.19
	far	250	-0.062	119.60	79.58	100.71	75.52
0		100	-0.138	53.71	35.74	45.23	33.92
		150	-0.097	76.51	50.93	64.44	48.33
		200	-0.075	99.14	66.01	83.51	62.65
		250	-0.061	121.70	81.05	102.52	76.92
		300	-0.051	144.21	96.06	121.50	91.17
		350	-0.044	116.70	111.05	140.46	105.40
		400	-0.039	189.17	126.03	159.40	119.62
		450	-0.035	211.63	141.01	178.34	133.83
		500	-0.032	234.10	155.98	197.27	148.05
		550	-0.029	256.55	170.95	216.20	162.15
		600	-0.027	278.99	185.92	253.12	176.46
		650	-0.025	301.43	200.88	254.04	190.66
		700	-0.023	323.87	215.84	272.95	204.85
		800	-0.020	368.74	245.75	310.78	233.25
		900	-0.018	413.60	275.67	348.60	261.65
	1000	-0.016	458.46	305.58	386.41	290.03	