

MVL-HF0624M-10MP

1/1.8" 6mm 10MP FA LENS

HF-P series FA Lens are optimized for machine vision light sources and sensor, with high resolution, excellent image quality, high transmittance and good stability. Featured with fixed focal length, manual aperture and compact size, it is suitable for machine vision industry applications and ideal for industrial cameras.



Key Features

- Ultra high resolution and consistency of image clarity
- Bigger aperture, lower distortion and higher relative illumination rate
- Achromatic optical system design. Better imaging performance with color camera
- Excellent vibration resistance performance, optical axis shifting within pixel level
- Good stability at high and low temperature
- Multilayer and broadband coating design, compatible with visible and near-infrared applications

Distortion

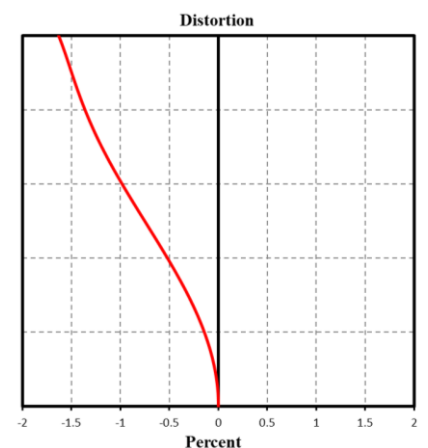

MTF

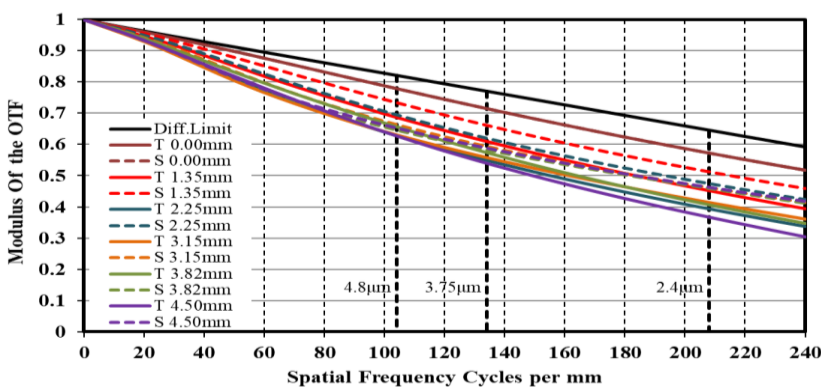

Relative Illumination

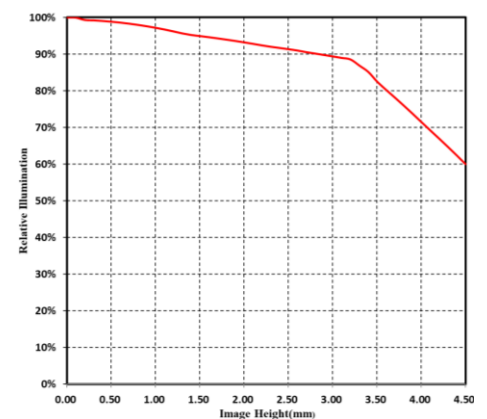

Note: The above curves are the simulate results based on F2.4, $\beta = -0.019$, WD=300 mm.

Specification

Parameter	Model	MVL-HF0624M-10MP
		Fixed focal length, Manual iris, 10MP, FA Lens
Performance		
Focal length		6 mm
F-number		F2.4 to F16
Image size		Ø9 mm (1/1.8")
Distortion		0.37%
Minimum object distance		0.1 m
Field of view		D (8.96 mm): 72.96° H (7.38 mm): 62.46° V (4.92 mm): 44.05°
Mechanical		
Iris control		Manual
Focus control		Manual
Mount		C-mount
Flange back length		17.526 mm
Dimension		Ø29.8 mm × 40.9 mm (Ø1.2" × 1.6")
Weight		82.8 g (0.2 lb.)
Temperature		-10°C to 50°C (14 °F to 122 °F)
General		
Certification		RoHS 2.0

Dimension

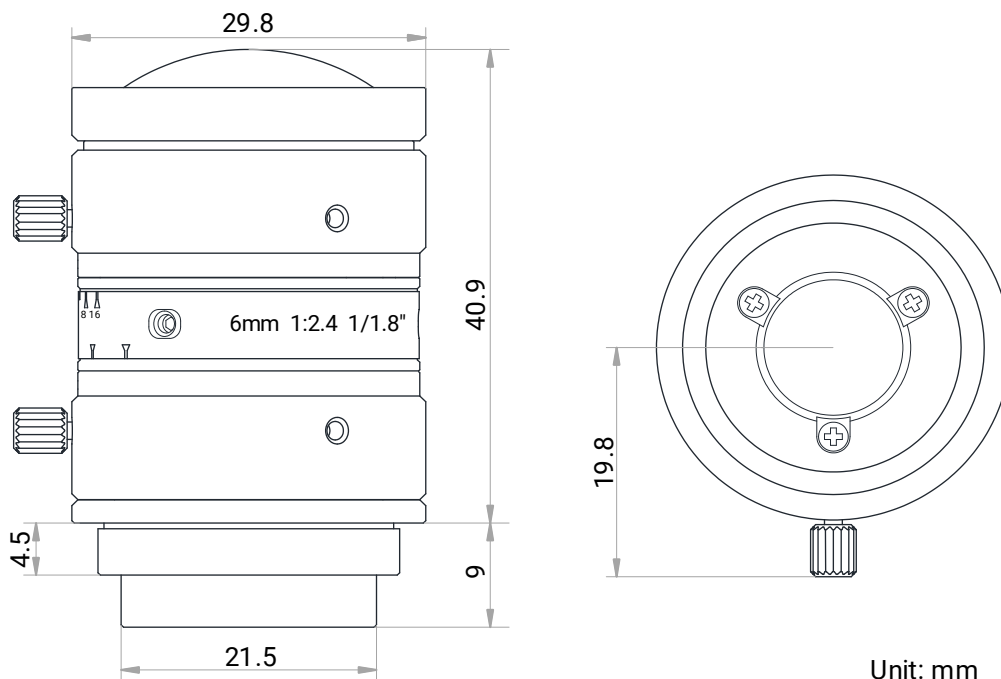

Field of View

Extension (mm)	Working Distance (mm)		Magnification	Field of View (mm)			
				1/1.8"		1/2"	
				H(7.38mm)	V(4.92mm)	H(6.22mm)	V(4.67mm)
1	near	13.3	-0.217	36.82	23.48	30.32	22.21
	far	21.1	-0.166	47.85	30.66	39.50	29.01
0		100	-0.054	140.47	92.54	117.71	87.74
		150	-0.037	202.11	133.55	169.64	126.65
		200	-0.028	263.64	174.51	221.50	165.52
		250	-0.023	325.27	215.55	273.45	204.45
		300	-0.019	386.74	256.48	325.26	243.29
		350	-0.017	448.13	297.38	377.02	282.09
		400	-0.015	509.66	338.36	428.89	320.98
		450	-0.013	571.09	379.27	480.68	359.80
		500	-0.012	632.63	420.26	532.56	398.70
		550	-0.011	694.03	461.16	584.32	437.50
		600	-0.010	755.49	502.10	636.14	476.35
		650	-0.009	816.87	542.99	687.88	515.14
		700	-0.008	878.46	584.01	739.80	554.07
		800	-0.007	1001.42	665.92	843.47	631.78
	900	-0.007	1124.39	747.83	947.83	709.51	
	1000	-0.006	1247.15	829.60	1050.64	787.10	