

MV-CT*M/CU0032/G

3.2 MP USB 3.0 Area Scan Camera



GEN<i>i>CAM

USBTM
VISION

Introduction

Designed for industrial applications, MV-CT*M/CU0032/G camera offers industry-leading performance and reliability, with various versions to meet diverse application needs. It supports IP67 protection, expanded interfaces, and integration of liquid/electric lenses, light sources, and lens cap, creating a more flexible and efficient system.

Key Features

- The devices with PRO version and MAX version support waterproof connector.
- The devices with PRO version and MAX version adopt precision temperature control design for fast heat balance.
- The color devices with PRO version and MAX version support auto color correction based on multi-spectral fusion technology.
- The device with MAX version integrates lens and light source, enabling lens focusing and light source control.
- Adopts Type-C interface and supports higher transmission bandwidth.
- Compatible with USB3 Vision Protocol, GenICam Standard, and the third-party software based on the protocol and standard.

Applicable Industry

Electronic semiconductor, factory automation, food and beverage, medicine packaging, etc.

Available Model

- Mono camera (BASE):
MV-CT0MU0032/G/NN/NN
- Color camera (BASE):
MV-CT0CU0032/G/NN/NN
- Mono camera (PRO):
MV-CT1MU0032/G/NN/NN
- Color camera (PRO):
MV-CT1CU0032/G/NN/NN
- Mono camera (MAX):
MV-CT2MU0032/G/NN/NN
- Color camera (MAX):
MV-CT2CU0032/G/NN/NN

Sensor Quantum Efficiency

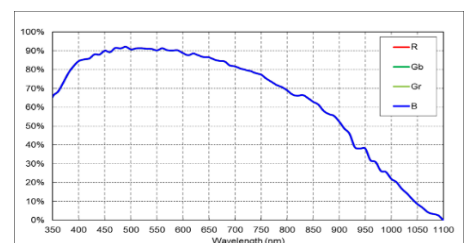

MV-CT*MU0032/G

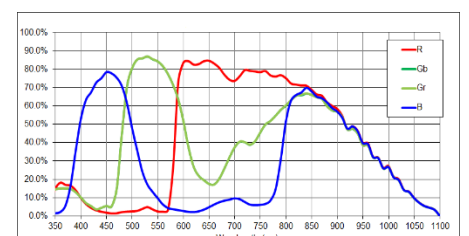

MV-CT*CU0032/G

Specification

Model	MV-CT*MU0032/G	MV-CT*CU0032/G
Performance		
Sensor type	CMOS, global shutter	
Sensor model	Stacked BSI	
Pixel size	3.45 μm × 3.45 μm	
Sensor size	1/1.8"	
Resolution	2048 × 1536	
Max. frame rate	104.8 fps @ 2048 × 1536 Mono 8	104.8 fps @ 2048 × 1536 Bayer GR 8
Dynamic range	74.4 dB	
SNR	42.4 dB	
Gain	High full well capacity: 0 dB to 12.8 dB High sensitivity: 0 dB to 24 dB	
Exposure time	High full well capacity: 30 μs to 10 sec High sensitivity: 5 μs to 10 sec	
Exposure mode	Off/Once/Continuous exposure mode, supports Trigger Width and Trigger Controlled	
Mono/color	Mono	Color
Pixel format	Mono 8/10/10Packed/12/12Packed	Mono 8, Bayer GR 8/10/10Packed/12/12Packed, YUV422Packed, YUV422_YUYV_Packed, RGB 8, BGR 8
Binning	Supports 1 × 1, 2 × 2, 4 × 4	
Decimation	Supports 1 × 1, 2 × 2, 4 × 4	
Reverse image	Supports horizontal and vertical reverse image output	
Electrical features		
Data interface	USB 3.0, compatible with USB 2.0	
Data interface type	Type-C interface	
Control interface	BASE + PRO: Not supported MAX: 8-pin M12 A-Code waterproof aviation connector	
Digital I/O	8-pin M8 A-Code aviation connector provides power and I/O, including opto-isolated input × 1 (Line 0), opto-isolated output × 1 (Line 1), bi-directional non-isolated I/O × 1 (Line 2).	
Power supply	9 VDC to 24 VDC, supports USB power supply	
Power consumption	BASE: Typ. 1.6 W @ 5 VDC (USB 3.0 provides power supply) PRO: Typ. 1.6 W @ 5 VDC (USB 3.0 provides power supply and fast heat balance not enabled) MAX: Typ. 1.6 W @ 5 VDC (USB 3.0 provides power supply, fast heat balance not enabled, and external device not be controlled)	

Mechanical	
Lens mount	C-mount
Dimension	BASE + PRO: 29 mm × 29 mm × 30 mm (1.1" × 1.1" × 1.2") MAX: 42 mm × 42 mm × 43 mm (1.7" × 1.7" × 1.7")
Weight	BASE: Approx. 72 g (0.2 lb.) PRO: Approx. 70 g (0.2 lb.) MAX: Approx. 109 g (0.2 lb.)
Ingress protection	BASE: IP40 (under proper lens installation and wiring) PRO+MAX: IP67 (under proper lens and lens cap installation and wiring)
Temperature	Working temperature: -30 °C to 60 °C (-22 °F to 140 °F) Storage temperature: -30 °C to 80 °C (-22 °F to 176 °F)
Humidity	20% RH to 95% RH (no condensation)
General	
Client software	MVS or third-party software meeting with USB3 Vision Protocol
Operating system	32/64-bit Windows 7/10, 64-bit Windows 11, 32/64-bit Linux
Compatibility	USB3 Vision, GenICam
Certification	CE, RoHS, KC

Dimension

BASE

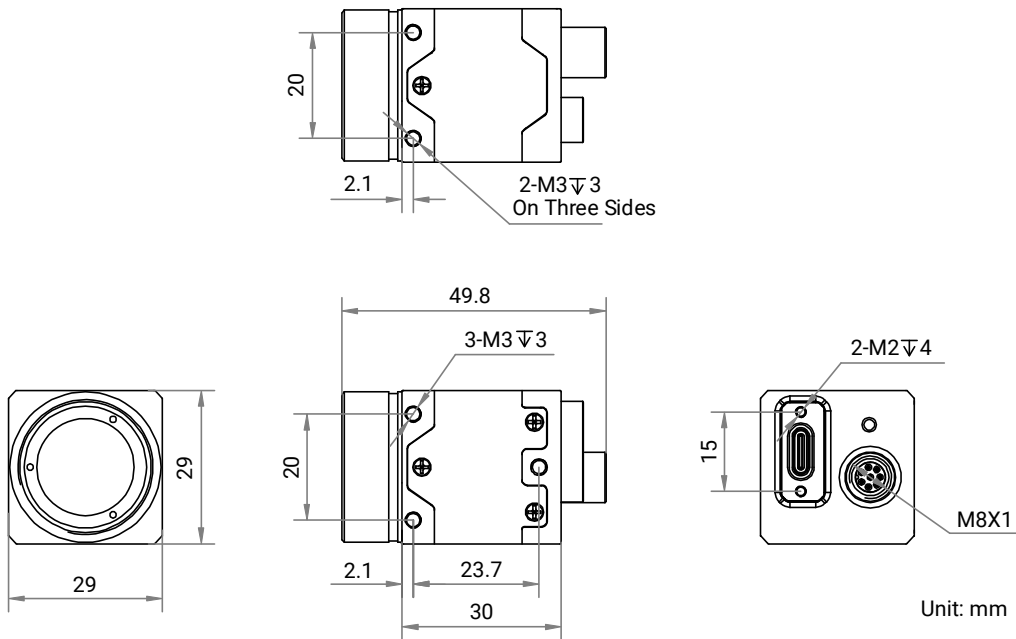

Dimension

PRO

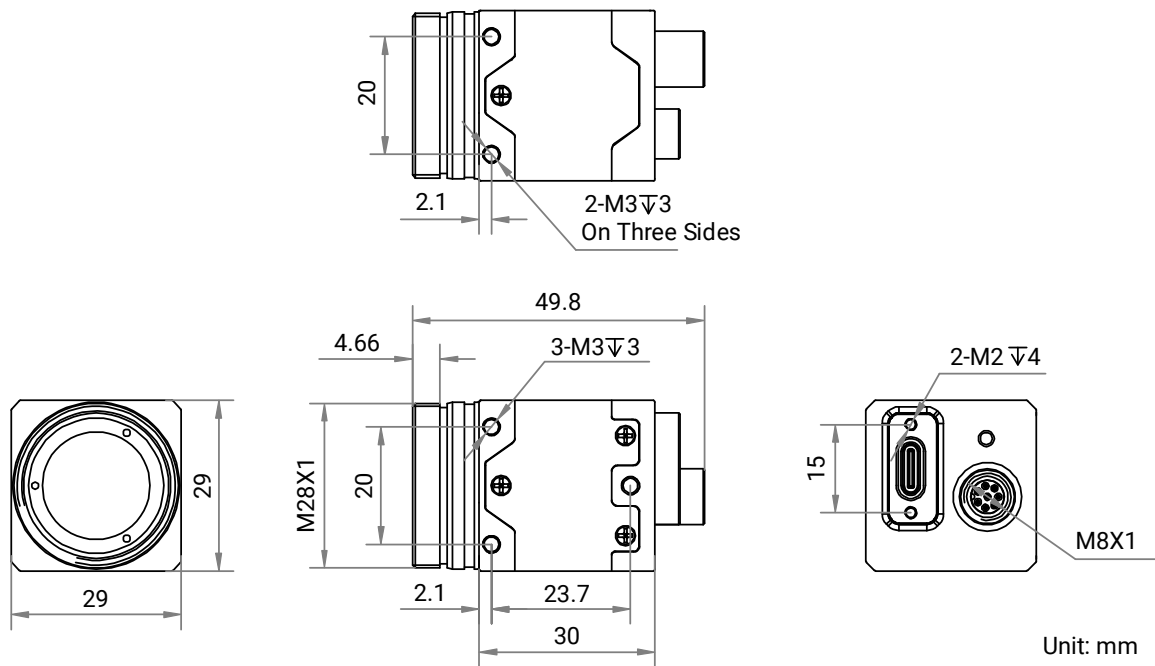

MAX

