

## MV-CT\*M/CG0032/G

### 3.2 MP GigE Area Scan Camera



GEN*i*CAM

GigE  
VISION

### Introduction

Designed for industrial applications, MV-CT\*M/CG0032/G camera offers industry-leading performance and reliability, with various versions to meet diverse application needs. It supports IP67 protection, expanded interfaces, and integration of liquid/electric lenses, light sources, and lens cap, creating a more flexible and efficient system.

### Key Feature

- The devices with PRO version and MAX version support waterproof connector.
- The devices with PRO version and MAX version adopt precision temperature control design for fast heat balance.
- The color devices with PRO version and MAX version support auto color correction based on multi-spectral fusion technology.
- The device with MAX version integrates lens and light source, enabling lens focusing and light source control.
- Adopts GigE interface and max. transmission distance of 100 meters without relay.
- Compatible with GigE Vision V2.0 Protocol, GenICam Standard, and third-party software based on the protocol and standard.

### Applicable Industry

Electronic semiconductor, factory automation, food and beverage, medicine packaging, etc.

### Available Model

- Mono camera (BASE):  
MV-CT0MG0032/G/NN/NN
- Color camera (BASE):  
MV-CT0CG0032/G/NN/NN
- Mono camera (PRO):  
MV-CT1MG0032/G/NN/NN
- Color camera (PRO):  
MV-CT1CG0032/G/NN/NN
- Mono camera (MAX):  
MV-CT2MG0032/G/NN/NN
- Color camera (MAX):  
MV-CT2CG0032/G/NN/NN

### Sensor Quantum Efficiency

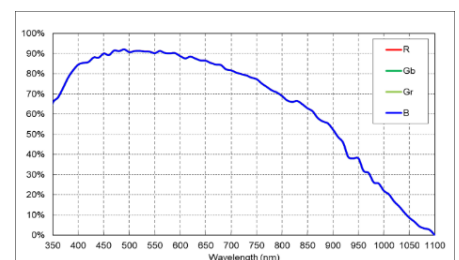

MV-CT\*MG0032/G

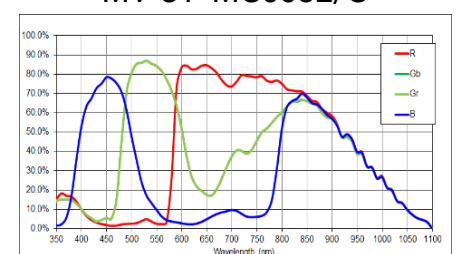

MV-CT\*CG0032/G

## Specification

Model	MV-CT*MG0032/G	MV-CT*CG0032/G
<b>Performance</b>		
<b>Sensor type</b>	CMOS, global shutter	
<b>Sensor model</b>	Stacked BSI	
<b>Pixel size</b>	3.45 $\mu\text{m}$ $\times$ 3.45 $\mu\text{m}$	
<b>Sensor size</b>	1/1.8"	
<b>Resolution</b>	2048 $\times$ 1536	
<b>Max. frame rate</b>	39 fps @ 2048 $\times$ 1536 Mono 8 77.5 fps @ 2048 $\times$ 1536 Mono 8 (PRO + MAX: lossless compression mode enabled)	39 fps @ 2048 $\times$ 1536 Bayer GR 8 77.5 fps @ 2048 $\times$ 1536 Bayer GR 8 (PRO + MAX: lossless compression mode enabled)
<b>Dynamic range</b>	73.9 dB	
<b>SNR</b>	42.4 dB	
<b>Gain</b>	High full well capacity: 0 dB to 12.8 dB High sensitivity: 0 dB to 24 dB	
<b>Exposure time</b>	High full well capacity: 30 $\mu\text{s}$ to 10 sec High sensitivity: 5 $\mu\text{s}$ to 10 sec	
<b>Exposure mode</b>	Off/Once/Continuous exposure mode, supports Trigger Width and Trigger Controlled	
<b>Mono/color</b>	Mono	Color
<b>Pixel format</b>	Mono 8/10/10Packed/12/12Packed	Mono 8, Bayer GR 8/10/10Packed/12/12Packed, YUV422Packed, YUV422_YUYV_Packed, RGB 8, BGR 8
<b>Binning</b>	Supports 1 $\times$ 1, 2 $\times$ 2, 4 $\times$ 4	
<b>Decimation</b>	Supports 1 $\times$ 1, 2 $\times$ 2, 4 $\times$ 4	
<b>Reverse image</b>	Supports horizontal and vertical reverse image output	
<b>Electrical features</b>		
<b>Data interface</b>	Gigabit Ethernet (1000 Mbit/s), compatible with Fast Ethernet (100 Mbit/s)	
<b>Data interface type</b>	BASE: RJ45 connector PRO + MAX: 8-pin M12 X-Code waterproof aviation connector	
<b>Control interface</b>	BASE + PRO: Not support MAX: 8-pin M12 A-Code waterproof aviation connector	
<b>Digital I/O</b>	8-pin M8 A-Code aviation connector provides power and I/O, including opto-isolated input $\times$ 1 (Line 0), opto-isolated output $\times$ 1 (Line 1), bi-directional non-isolated I/O $\times$ 1 (Line 2).	
<b>Power supply</b>	9 VDC to 24 VDC, supports PoE	
<b>Power consumption</b>	BASE: Typ. 1.5 W @ 12 VDC PRO: Typ. 1.5 W @ 12 VDC (fast heat balance not enabled) MAX: Typ. 1.6 W @ 24 VDC (fast heat balance not enabled and external device not be controlled)	BASE: Typ. 1.5 W @ 12 VDC PRO: Typ. 1.6 W @ 12 VDC (fast heat balance not enabled) MAX: Typ. 1.7 W @ 24 VDC (fast heat balance not enabled and external device not be controlled)

<b>Mechanical</b>	
<b>Lens mount</b>	C-mount
<b>Dimension</b>	BASE + PRO: 29 mm × 29 mm × 42 mm (1.1" × 1.1" × 1.7") MAX: 42 mm × 42 mm × 43 mm (1.7" × 1.7" × 1.7")
<b>Weight</b>	BASE: Approx. 116 g (0.3 lb.) PRO: Approx. 124 g (0.3 lb.) MAX: Approx. 120 g (0.3 lb.)
<b>Ingress protection</b>	BASE: IP40 (under proper lens installation and wiring) PRO + MAX: IP67 (under proper lens and lens cap installation and wiring)
<b>Temperature</b>	Working temperature: -30 °C to 60 °C (-22 °F to 140 °F) Storage temperature: -30 °C to 80 °C (-22 °F to 176 °F)
<b>Humidity</b>	20% RH to 95% RH (no condensation)
<b>General</b>	
<b>Client software</b>	MVS or third-party software meeting with GigE Vision Protocol
<b>Operating system</b>	32/64-bit Windows 7/10, 64-bit Windows 11, 32/64-bit Linux
<b>Compatibility</b>	GigE Vision V2.0, GenICam
<b>Certification</b>	CE, RoHS, KC

## Dimension

### BASE

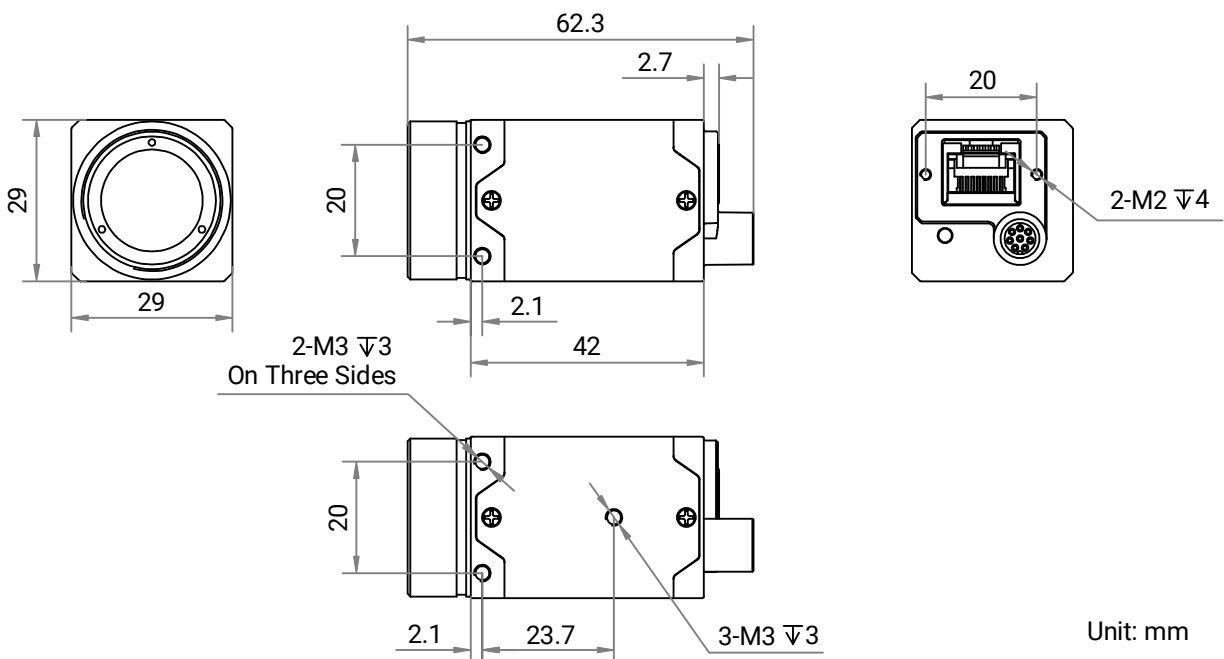

**Dimension**

**PRO**

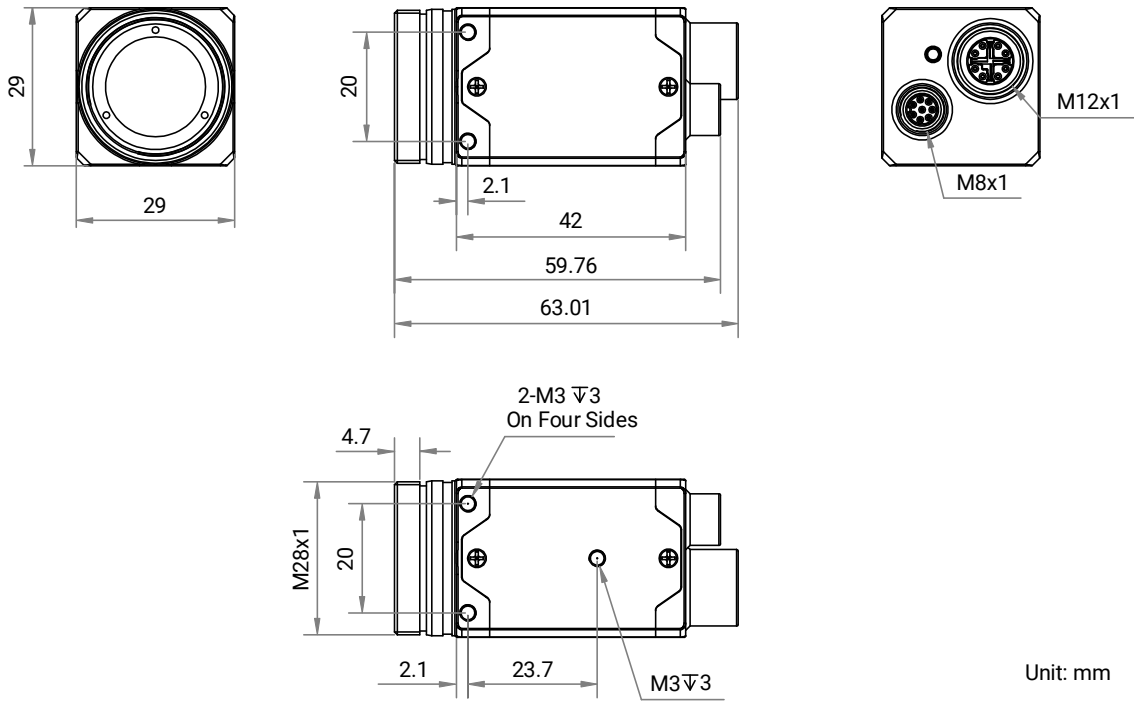

Unit: mm

**MAX**

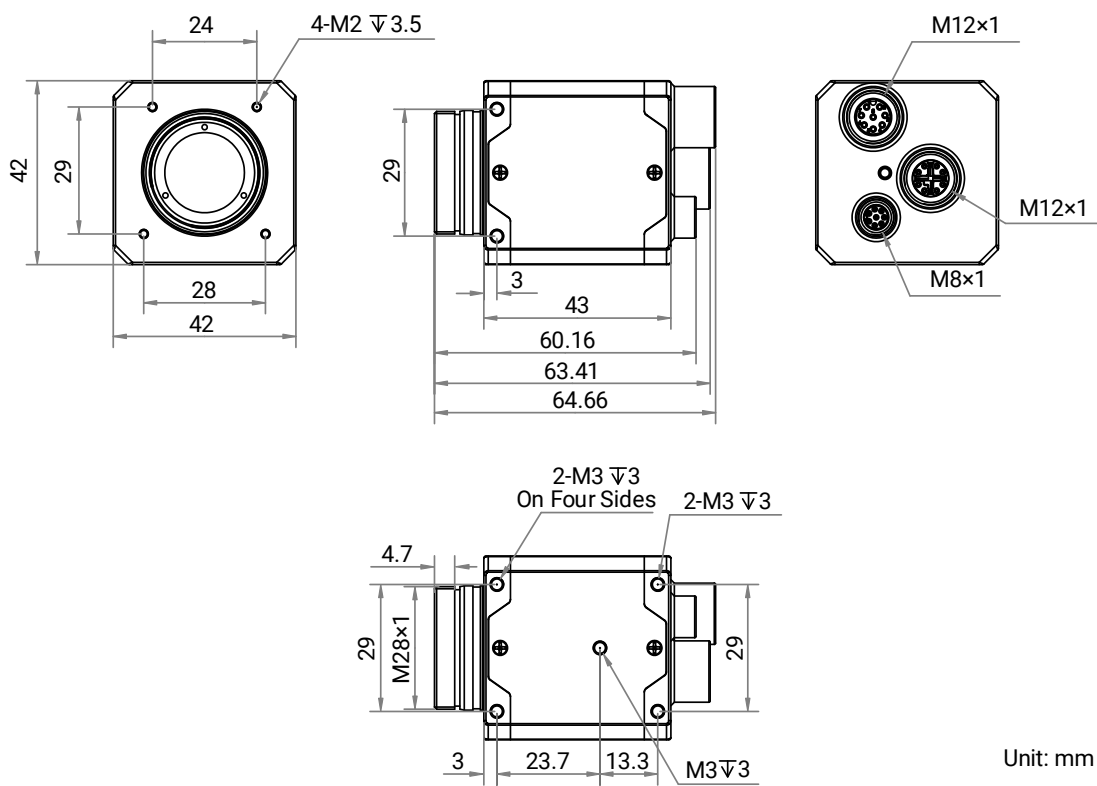

Unit: mm